

Perfect® MULTI-GYM® **PRO**

User Guide



©2017 Implus LLC • All rights reserved.
Perfect Fitness®, Perfect®, and Multi-Gym® are registered trademarks of Implus LLC.
U.S. and International Patents Pending.
www.PerfectOnline.com

No part of this booklet may be reproduced or utilized in any form or by any means electronic, mechanical or otherwise without the expressed written consent of the copyright holder.

Introduction

Getting in shape takes a positive attitude and determination. The right equipment makes achieving your fitness goals easier, so congratulations on your purchase of the Perfect Multi-Gym® Pro. The Perfect Multi-Gym® Pro is key to an effective, time-efficient exercise regimen. No matter your fitness level, you can progress at a rate that's right for you using Perfect Fitness products.

Sticking with a program of regular exercise takes persistence. We encourage you go to www.PerfectOnline.com to find out about new products, get workout tips and view workout videos.

Like us on Facebook at www.facebook.com/perfectfitness - it's a great place to share your progress. Follow us on Instagram [Perfect_Fitness_](https://www.instagram.com/Perfect_Fitness/) Many of our top users have created their own exercise routines using our products and use hashtag **#PerfectFitness**

IMPORTANT:

This Owner's Manual is the authoritative source of information about your Perfect Multi-Gym. Please read it carefully and follow all the instructions.

Comments or Questions?

If you have any comments or questions about your Perfect product, please email, call or write to our Customer Service Specialists. Our goal is your complete satisfaction.

Perfect® Customer Service Department, 2001 T.W. Alexander Drive, Box 13925, Durham, North Carolina 27709-3925

Call Toll Free: 1 877 974 7733, Monday through Friday, 8:00am to 5:00pm, EST
Email: help@4implus.com

www.PerfectOnline.com

Important Safety Information

▲ WARNING

FAILURE TO READ AND FOLLOW THE SAFETY INSTRUCTIONS STATED IN THIS USER GUIDE AND ON THE WORKOUT CHART MAY RESULT IN SERIOUS INJURY, DEATH OR PROPERTY DAMAGE.



1) **Consult your physician before starting this or any other exercise program.** Fitness training can result in serious injury or death. Risk of injury can be lessened when safe technique and common sense are practiced. **Before beginning your first workout, become familiar with the Perfect-Multi-Gym® and review all exercise guidelines prior to using the equipment. If you have any questions consult your physician.** Your physician should assist you in determining the target heart rate zone appropriate for your age and physical condition. Certain exercise programs or types of equipment may not be appropriate for all people. This is especially important for people over the age of 35, pregnant women, or those with preexisting health problems or wrist, elbow, shoulder or other joint and muscle impairments. **If you are taking medication which may affect your heart rate, a physician's advice is absolutely essential before use of this equipment.**

2) **Warm up** before any exercise program by doing 5 to 10 minutes of gentle aerobic exercise, such as walking, followed by stretching.

3) **Start out slowly and progress sensibly.** Even if you are an experienced exerciser, start with the beginner workout and become familiar with all of the exercises before moving on to more advanced workouts or exercises.

4) **Do not overexert yourself with this or any other exercise program.** Listen to your body and respond to any reactions you may be having. You must learn to distinguish "good" pain, like fatigue, from "bad" pain, which hurts. **If you experience any pain or tightness in your chest, an irregular heartbeat, dizziness, nausea, or shortness of**

breath, stop exercising at once and consult your physician immediately.

5) **Before EACH use, visually inspect the equipment. Never use this equipment if it is not working properly or if there are damaged or worn parts.** Call our Customer Service Department to order replacement parts.

6) **Use this equipment ONLY for the intended use as described by the manufacturer. DO NOT** modify the equipment or use attachments not recommended by the manufacturer.

7) **Have plenty of clearance space on all sides of your equipment.** It is important to keep children, pets, furniture and other objects out of the way when using your equipment to avoid unnecessary contact.

8) **Wear appropriate clothing when exercising.** Workout clothing should be comfortable and lightweight, and should allow freedom of movement. Wear comfortable athletic shoes made of good support with non-slip soles, such as running or aerobic shoes.

9) **THIS EQUIPMENT IS NOT FOR USE BY CHILDREN. To prevent injuries, keep this and all fitness equipment out of the reach of children. Follow these simple rules:**

- Keep children out of rooms where you have your exercise equipment.
- Store exercise equipment in a room that can be locked.
- Know exactly where your children are when you work out.
- If you have small children at home, don't wear headphones while you work out.
- Talk to your kids about the dangers of exercise equipment.

Equipment Warning Label

IMPORTANT: See below for placement of this Warning Label on your equipment.

⚠ WARNING

Failure to read and follow the safety instructions in the Owner's Manual and this Warning Label may result in **SERIOUS INJURY OR DEATH. KEEP CHILDREN AWAY.** Inspect the equipment before each use. Never use the equipment if it is damaged and/or not functioning properly. When attaching the Multi-Gym® Pro to a door frame, make sure the Safety Clip is securely attached to both the molding and Multi-Gym Pro. Remove the Multi-Gym Pro from the door frame when not in use. Do not use if you weigh over 300 lbs/136 kg. Replace this label if damaged, illegible or removed. Class HC. Go to our website: www.perfectonline.com or call Customer Service: 1 877 974 7733 for replacement label, user guide or questions.

10) **Breathe naturally**, never holding your breath during an exercise. Avoid over-training. You should be able to carry on a conversation while exercising.

11) **Cool down after an exercise session** with 5 to 10 minutes of gentle aerobic exercise, such as walking, followed by stretching.

12) **Handicapped, disabled, or injured people must have medical approval** before using this equipment and should be under close supervision when using any exercise equipment.

13) **ONLY one person at a time should use this equipment.**

14) **DO NOT store in direct sunlight or near direct heat sources.**

15) **DO NOT put hands, feet or any foreign objects on or near this equipment when in use by others.** Use caution to not pinch fingers or hands in moving parts when setting up or using the equipment.

16) The Perfect Multi-Gym® is designed and constructed for **PERSONAL OR HOUSEHOLD USE ONLY**. The Perfect Multi-Gym® should NOT be used in commercial settings including, without limitation, health clubs and fitness centers. Further, use of the Perfect Multi-Gym® in a commercial setting or resale by an unauthorized dealer voids the warranty. See Limited Warranty Card for details.

17) When attaching the Multi-Gym® to a door frame, **make sure the Safety Clip is securely attached to both the Molding and Multi-Gym®. Remove the Multi-Gym® from the door frame when not in use.**

18) **Do not install this product unless you are able to assemble and install it properly. After installing this product, check to make sure it has been properly installed and can support your full weight before beginning exercise. This product is designed for installation on up-to-building-code, wood-frame doorways, 27 to 33 inches (69 – 84 cm) wide and do not use this product if you weigh more than 300 lbs/136 kg. If the product is moved to a different door, you must recheck the fit and adjust the product to fit the new doorway if necessary.** Any other use or misuse may result in property damage and/or personal injury. If your anticipated installation location or use does not meet these criteria, you may return the product for up to 365 days from date of purchase.

19) **When performing pullups**, never pull up with bar behind head, as this places undue stress on shoulders and neck. Also, when performing pullups, avoid crossing feet during exercise, as this places hips in an uneven position which impacts body alignment.

Specifications & Parts

Length: 38-1/2" **Width:** 19-1/2" **Height:** 7-3/4"

Product Weight: 6.4 lbs. **Maximum User Weight:** 300 lbs./136 kg.

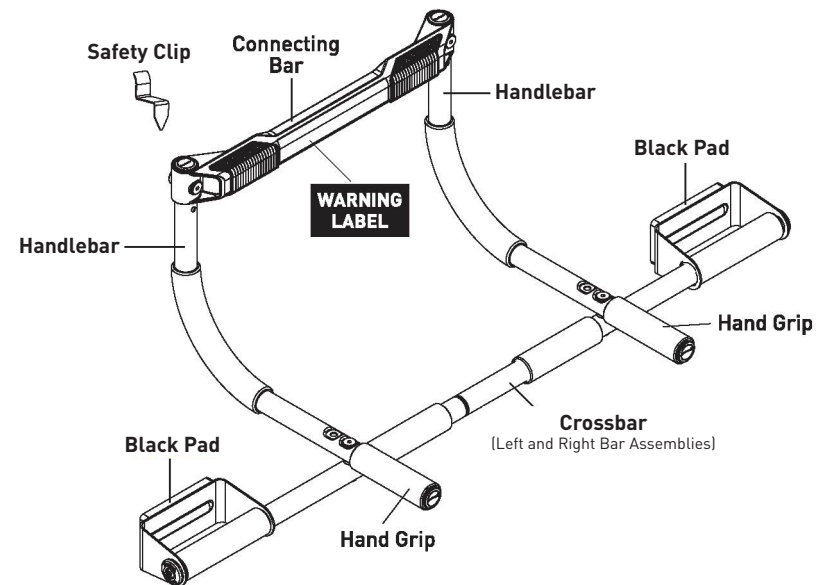

Assembly Instructions

Read and follow all instructions provided before assembling or installing this product. Failure to properly assemble or install this product could result in damage to property and/or personal injury. Do not install this product unless you are able to assemble and install it properly. After installing this product, check to make sure it has been properly installed and can support your full weight before beginning exercise. This product is designed for installation on up-to-building-code, wood-frame doorways, 27 to 33 inches (69 - 84 cm) wide and for use by individuals weighing no more than 300 lbs/136 kg. Any other use or misuse may result in property damage and/or personal injury. If your anticipated installation location or use does not meet these criteria, you may return the product for up to 365 days from date of purchase.

LAY OUT THE PARTS of your Perfect Multi-Gym® as shown below and familiarize yourself with the parts for easier assembly.

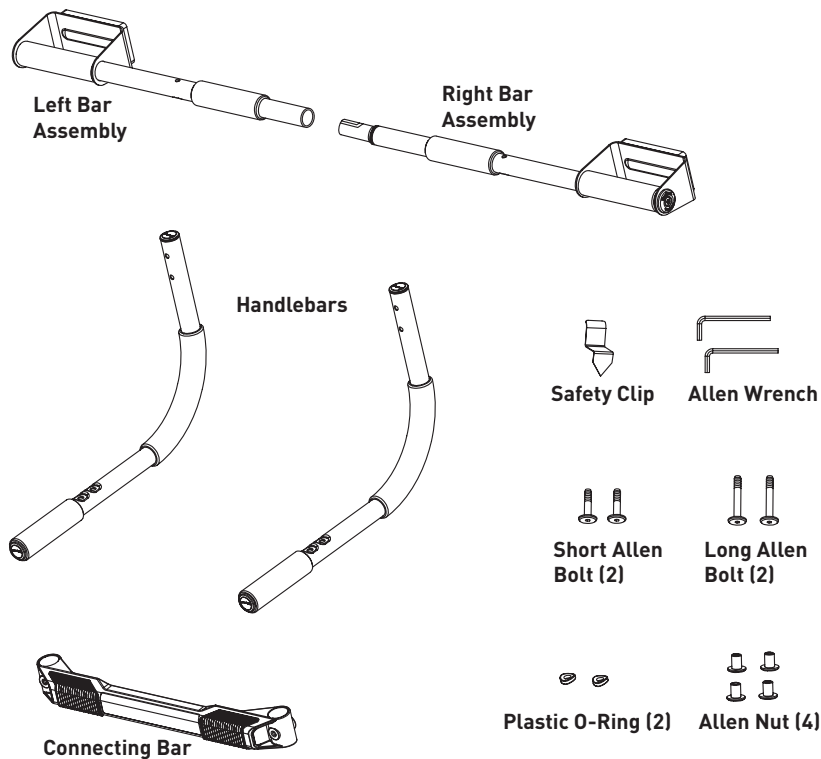

STEP 1

- a) To begin assembly, place Left and Right bars on table with pads facing down.
- b) Attach the Left and Right Bar Assembly together by first sliding the Right Bar Assembly into the Left Bar Assembly.

Note: the LEFT Bar Assembly is keyed to the RIGHT Crossbar Assembly with an "L-shaped" channel.

- c) Hand - fasten the two bar assemblies together by turning the LEFT Bar Assembly counter clock-wise.

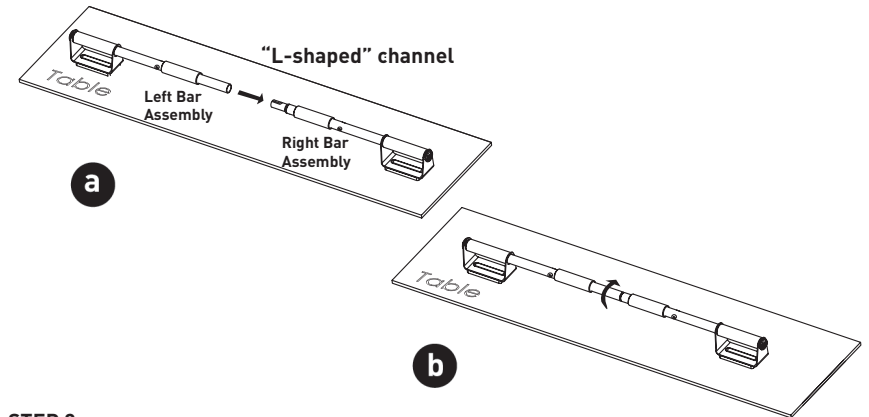

STEP 2

- a) Locate the holes on the LEFT and RIGHT Curved Tube Assembly. Insert the LONG Allen Bolt into the hole of the LEFT and RIGHT Curved Tube Assemblies.
- b) Place the Plastic O-Ring onto the end of the Allen Bolt prior to assembly with the Crossbar. Insert the end of the LONG Allen Bolt into the top hole of the Crossbar, and insert an Allen Nut into the bottom hole of the Crossbar. Start by hand-tightening the nut into the bolt.
- c) Repeat step "B" for both of the Curved Tube Assembly

NOTE: Doorway Installation is necessary before tightening all Allen Nut assemblies.

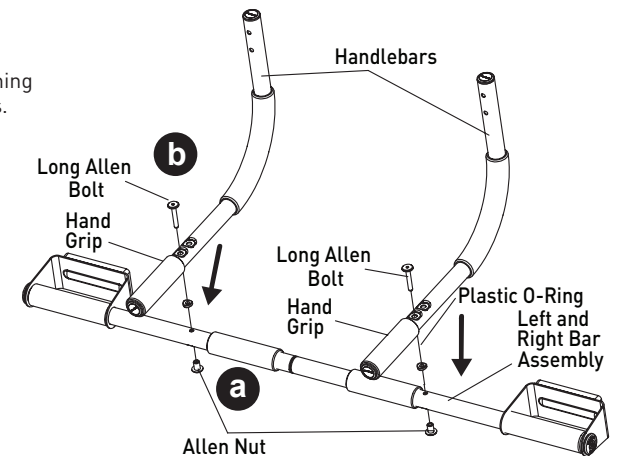

STEP 3

a) While the assembly is in front of you as shown, Attach the Connector Bar to the LEFT and RIGHT Curved Tube Assemblies. Make sure to line up the holes of the connector bar with the holes on the Curved Tube Assemblies.

b) Insert the SHORT Allen Bolt through the hole in front of the Connector Bar, and in the hole in the Curved Tube Assembly. Insert an Allen Nut into the hole on the back of the Connector Bar and hand tighten.

c) Repeat step "B" for both sides of the Connector Bar and Curved Tube Assemblies.

d) Once all of the components are assembled, use the two Allen Wrenches provided to tighten all of the nuts and bolts.

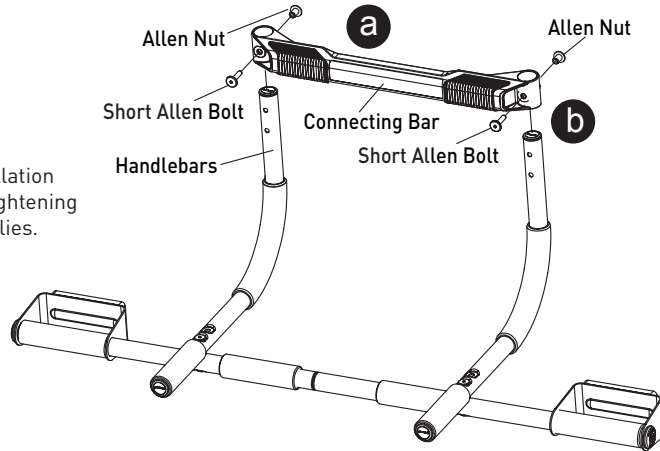

NOTE: Doorway Installation is necessary before tightening all Acorn Nut assemblies.

Installation Of Your Multi-Gym®

Before installing in the doorway you will be using, acquaint yourself with the photos and definitions below. Please remember, this product is designed for installation on up-to building-code, wood-frame doorways, 27 to 33 inches (69 - 84 cm) wide and for use by individuals weighing not more than 300 lbs/136 kg.

1) Identify Front and Back of unit.

2) Inside and outside of Doorway.

Outside of Doorway

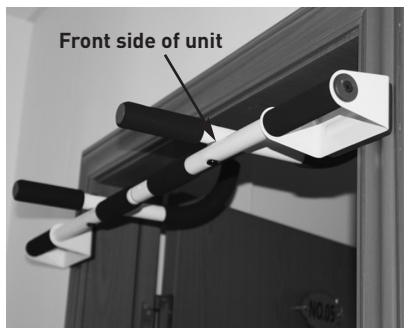

Inside of Doorway

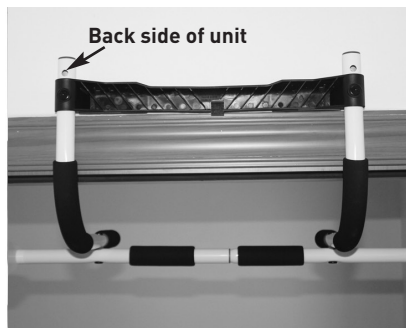

Multi-Gym® Adjustments

Door frames and trim (molding) vary in size. The Perfect Multi-Gym® has 2 adjustments to accommodate different molding heights (Figures A and B) and 2 adjustments to accommodate different doorway thicknesses (Figures C and D).

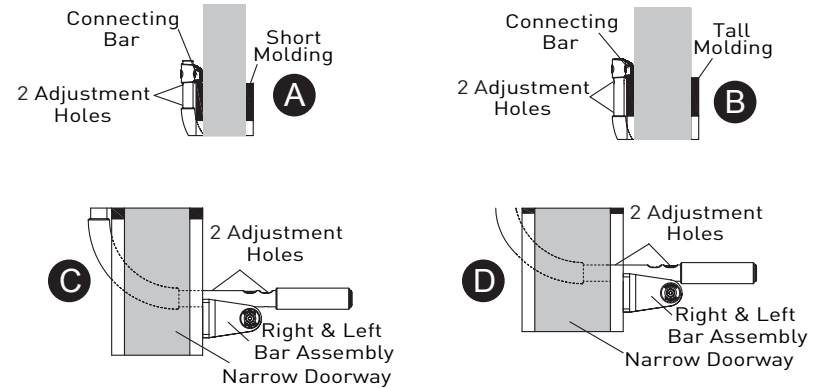

Doorway Installation

STEP 1 - Fitting the Multi-Gym® to your Doorway

After assembling the unit, try it in the door. You may need to move the bolt positions to get a proper fit. The unit is correctly fitted in the doorway when it sits snugly at the top of the door frame and the Hand Grips are level with the floor.

Warning: Remove the Multi-Gym® from the door frame before making any Bolt adjustments. Failure to follow this instruction may result in serious injury or death.

a) From the outside of the doorway (the side that does not have the hinges), angle the Connecting Bar end through the doorway and over the molding on the opposite side (the inside of the doorway).

b) Adjust the Left and Right Bar Assemblies to match the thickness of the doorway. When properly adjusted, the Black Pads on the Left and Right Bar Assemblies should be flush with the wall and molding. See Figures C and D shown above.

c) Adjust the Connecting Bar to match the width of the door molding. See Figures A and B shown above. If the fit is too loose, it will appear like the Incorrect Position shown in Figure E. You will need to move the Left and Right Bar Assembly away from the Hand Grip.

d) After all adjustments have been made, see Figure F for correct positioning. Tighten the 2 Long and 2 Short Allen Bolts with tool provided. Refer to page 7, Step 2b and page 8, Step 3b.

INCORRECT POSITION

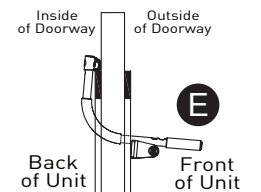

CORRECT POSITION

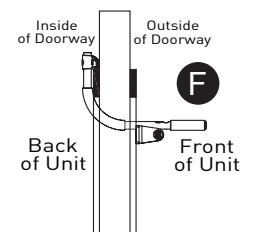

STEP 2 - Installing the Safety Clip

After the Multi-Gym® has been adjusted to fit the doorway, remove it from the doorway and install the Safety Clip.

a) On the inside of the doorway, place the Safety Clip above the molding in the center at the top of the door.

b) Slide the pointed end between the wall and the molding. Push downward until Safety Clip is flush against the molding. Reinstall the Multi-Gym® in the doorway.

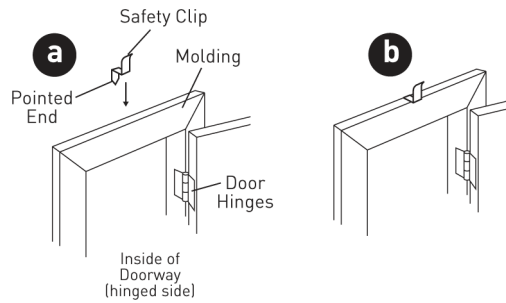

Warning: When attaching the Multi-Gym® to a door frame, make sure the Safety Clip is securely attached to both the molding and Multi-Gym®. Failure to follow this instruction may result in serious injury or death.

Completed Installation

You can reinstall the Multi-Gym® in the doorway once the Safety Clip is installed. When properly installed, the Multi-Gym® will fit in the doorway as shown below.

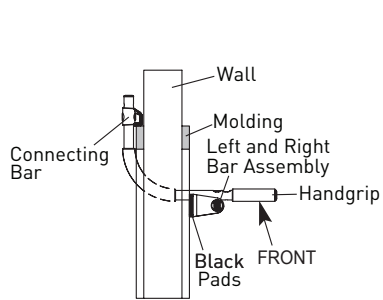

Side View

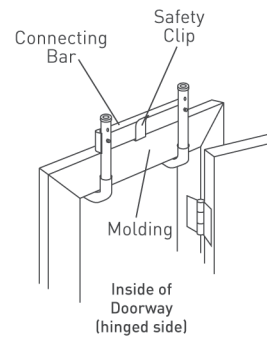

View from Inside Doorway

Warning: Remove the Multi-Gym® from the door frame when not in use. If the product is moved to a different door, you must recheck the fit and adjust the product to fit the new doorway if necessary. Failure to follow these instructions may result in serious injury or death.

Parts List & Exploded View

Door frames and trim (molding) vary in size. The Perfect Multi-Gym® has 2 adjustments to accommodate different molding heights (Figures A and B under Multi-Gym® adjustments) and 2 adjustments to accommodate different doorway thicknesses (Figures C and D under Multi-Gym® adjustments).

ITEM#	PART#	DESCRIPTION	QTY	ITEM#	PART#	DESCRIPTION	QTY
1		Left Bar Assembly	1	12		Plastic O-Ring	2
2		Right Bar Assembly	1	18		Hand Grip	2
3		Handlebar Assembly	2	20		Safety Clip	1
5		M6x28mm Allen Bolt	2	21		Allen Wrench	2
7		M6x42mm Allen Bolt	2				
8		M6 Allen Nut	4				
9		M6x16mm Allen Bolt	2				
10		Connecting Bar	1				

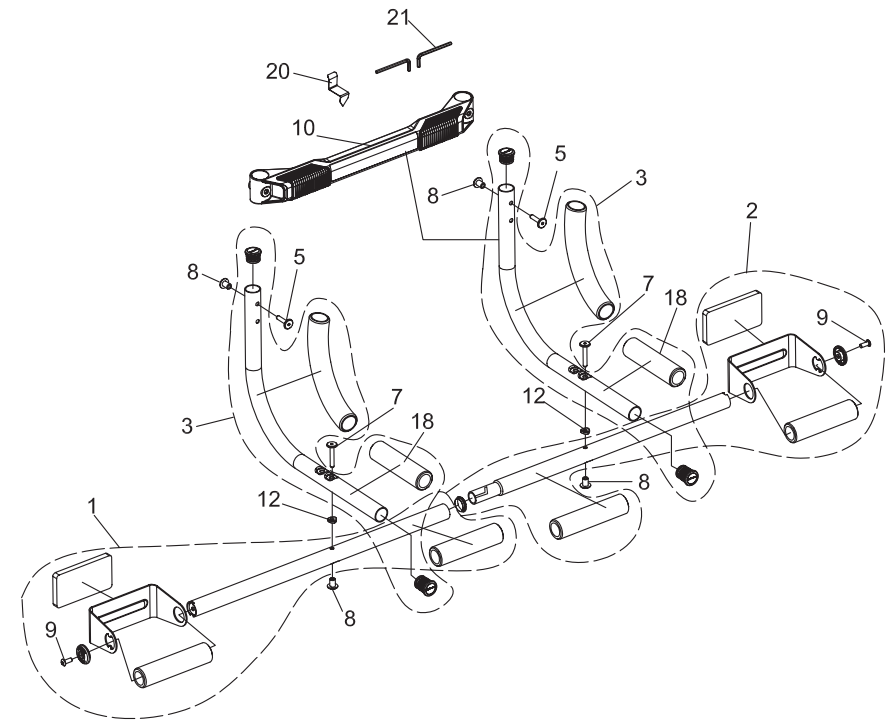

Warning

Before each use, visually inspect the device. Never use the device if it is not working properly.

Care & Storage

Your Perfect® product has been carefully designed to require minimum maintenance. To ensure this, we recommend that you do the following:

Keep your unit clean.

Wipe sweat, dust or other residue off the bar with a soft, clean cloth after each use.

To store your unit after use.

Store your device out of the reach of children and high traffic areas.

Workouts

Go to www.perfectonline.com/workouts to download free workout guides. The downloadable content concentrates on four key aspects of fitness: Core, Push, Pull and Strength. When combined, the Perfect® products and programs create the perfect full body workout solution.